

STROKE	A	B
0.50 [12.7]	11.25 [285.8]	0.50 [12.7]
1.00 [25.4]	11.75 [298.5]	0.50 [12.7]
1.50 [38.1]	12.25 [311.2]	0.50 [12.7]
2.00 [50.8]	12.75 [323.9]	0.50 [12.7]
2.50 [63.5]	13.25 [336.6]	0.50 [12.7]
3.00 [76.2]	13.75 [349.3]	0.50 [12.7]
3.50 [88.9]	14.25 [362.0]	0.50 [12.7]
4.00 [101.6]	14.75 [374.7]	0.50 [12.7]
4.50 [114.3]	15.75 [400.1]	1.00 [25.4]
5.00 [127]	16.75 [425.5]	1.50 [38.1]
5.50 [139.7]	17.75 [450.9]	2.00 [50.8]
6.00 [152.4]	18.75 [476.3]	2.50 [63.5]
6.50 [165.1]	19.75 [501.7]	3.00 [76.2]
7.00 [177.8]	20.75 [527.1]	3.50 [88.9]
7.50 [190.5]	21.75 [552.5]	4.00 [101.6]
8.00 [203.2]	22.75 [577.9]	4.50 [114.3]

STROKE TOLERANCE
NOMINAL + 0.000 / - 0.015 [+0.0 / -0.4]

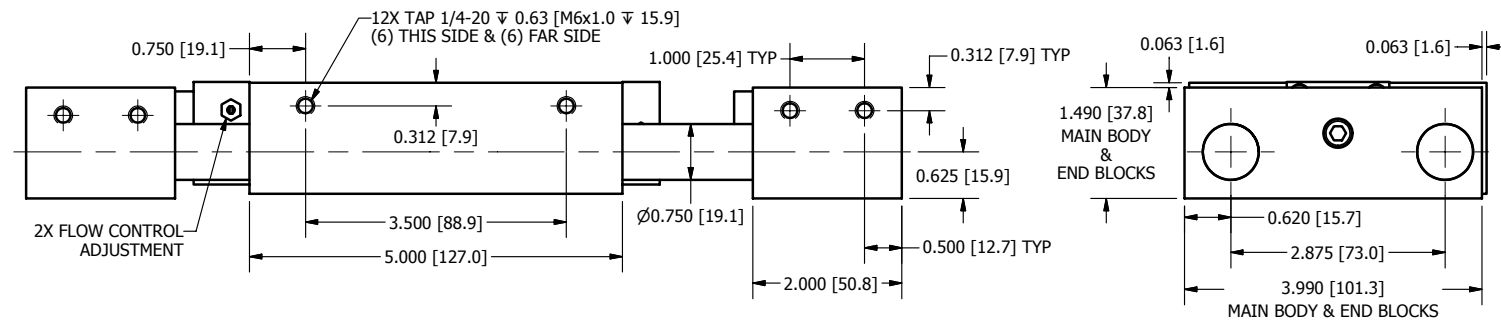

DURA-SLIDE
AIR-30