

NOTE: UNIT SHOWN AT MIDDLE OF STROKE
(1/2 OF TOTAL ROTATION)

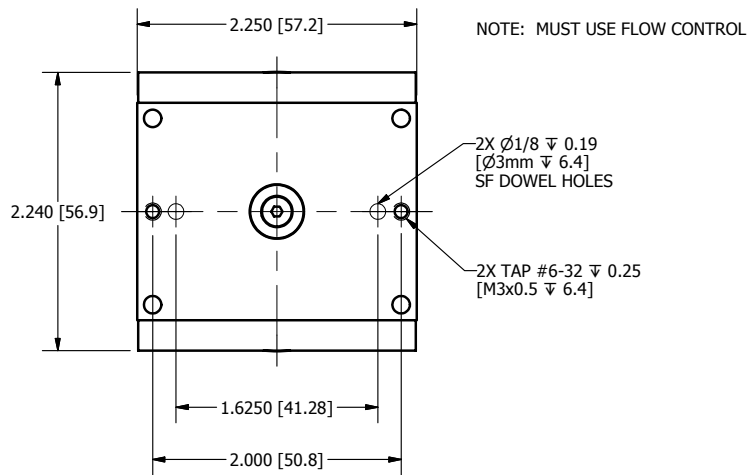
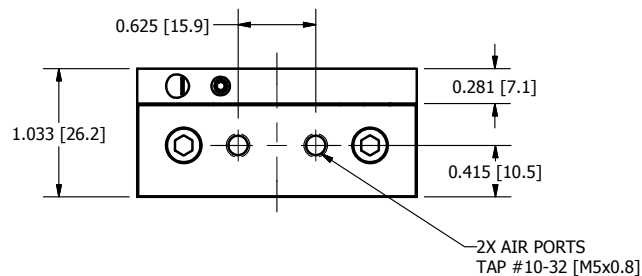
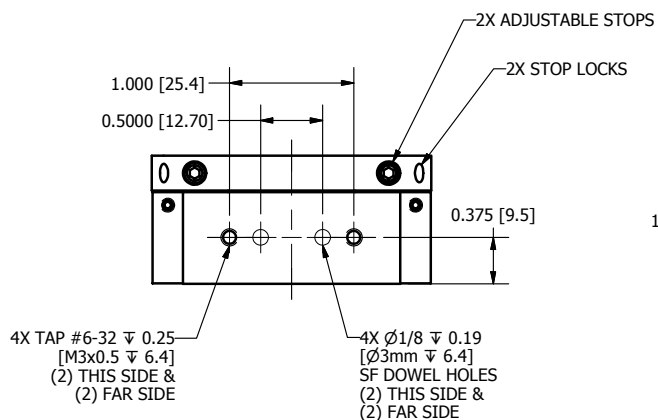

DURA-TAC
SRA-1